

# Where Do You Get Your Name?

Genesis 11:1-32

# Where Do You Get Your Name? Genesis 11:1-32

For even though I am absent in body, nevertheless I am with you in spirit, **rejoicing to see your good discipline and the stability of your faith in Christ.** 6 Therefore as you have received Christ Jesus the Lord, so walk in Him, 7 having been firmly rooted and now being built up in Him and established in your faith, just as you were instructed, and overflowing with gratitude. 8 **See to it that no one takes you captive through philosophy and empty deception, according to the tradition of men, according to the elementary principles of the world, rather than according to Christ.**

Colossians 2:5–8

# Where Do You Get Your Name? Genesis 11:1-32

Then he **believed** in the LORD; and **He reckoned it to him as righteousness.** Genesis 15:6

# Where Do You Get Your Name? Genesis 11:1-32

Then he **believed** in the LORD; and **He reckoned it to him as righteousness**. Genesis 15:6

For if Abraham was justified by works, he has something to boast about, but not before God. 3 For what does the Scripture say? “**ABRAHAM BELIEVED GOD, AND IT WAS CREDITED TO HIM AS RIGHTEOUSNESS.**” Romans 4:2–3

Is this blessing then on the circumcised, or on the uncircumcised also? For we say, “**FAITH WAS CREDITED TO ABRAHAM AS RIGHTEOUSNESS.**” 22 Therefore **IT WAS ALSO CREDITED TO HIM AS RIGHTEOUSNESS.** Romans 4:9, 22

Even so Abraham **BELIEVED GOD, AND IT WAS RECKONED TO HIM AS RIGHTEOUSNESS.** Galatians 3:6

and the Scripture was fulfilled which says, “**AND ABRAHAM BELIEVED GOD, AND IT WAS RECKONED TO HIM AS RIGHTEOUSNESS,**” and **he was called the friend of God.** James 2:23

# Where Do You Get Your Name? Genesis 11:1-32

“But we were hoping that it was He who was going to redeem Israel.  
Indeed, besides all this, it is the third day since these things happened.  
Luke 24:21

# Where Do You Get Your Name? Genesis 11:1-32

“But we were hoping that it was He who was going to redeem Israel. Indeed, besides all this, it is the third day since these things happened. **25 And He said to them, “O foolish men and slow of heart to believe in all that the prophets have spoken! 26 “Was it not necessary for the Christ to suffer these things and to enter into His glory?”** 27 Then beginning with Moses and with all the prophets, He explained to them the things concerning Himself in all the Scriptures. Luke 24:21, 25-26

# Where Do You Get Your Name? Genesis 11:1-32

“But we were hoping that it was He who was going to redeem Israel. Indeed, besides all this, it is the third day since these things happened. **25 And He said to them, “O foolish men and slow of heart to believe in all that the prophets have spoken! 26 “Was it not necessary for the Christ to suffer these things and to enter into His glory?” 27** Then beginning with Moses and with all the prophets, He explained to them the things concerning Himself in all the Scriptures. Luke 24:21, 25-27

# Where Do You Get Your Name? Genesis 11:1-32

“But we were hoping that it was He who was going to redeem Israel. Indeed, besides all this, it is the third day since these things happened. **25 And He said to them, “O foolish men and slow of heart to believe in all that the prophets have spoken! 26 “Was it not necessary for the Christ to suffer these things and to enter into His glory?” 27** Then beginning with Moses and with all the prophets, He explained to them the things concerning Himself in all the Scriptures. Luke 24:21, 25-27

**“The New Testament is in the Old Concealed; the Old Testament is in the New revealed.” Augustine**



# Where Do You Get Your Name? Genesis 11:1-32

27 Then beginning with Moses and with all the prophets, He explained to them the things concerning Himself in all the Scriptures. Luke 24:27

**“The New Testament is in the Old Concealed; the Old Testament is in the New revealed.” Augustine**

“Jesus did not arrive unannounced; his coming was declared in advance in the Old Testament—not just in explicit prophecies of the Messiah, but also by means of the stories of all the events, characters, and circumstances in the Old Testament.” God was telling a larger, overarching, unified story. From the account of creation in Genesis to the final stories of the return from exile, God progressively unfolded his plan of salvation. And the Old Testament account of that plan always pointed in some way to Christ.”

Iain Duguid

# Where Do You Get Your Name? Genesis 11:1-32

# Where Do You Get Your Name? Genesis 11:1-32

## I. A Legacy From Earth to Heaven vv. 1-9



0 25 50 75 100 mi  
0 50 100 150 km

Map created using Biblemapper 5.  
<https://biblemapper.com/index.html>



0 50 mi

# The Tower of Babel



**Stairs**

The Tower of Babel would have been built in ziggurat form. It probably was ancient Babylon's Etemenanki—the "temple of the foundation of heaven and earth." Many Babylonian legends and documents describe this structure, as does the Greek historian Herodotus.

# The Tower of Babel

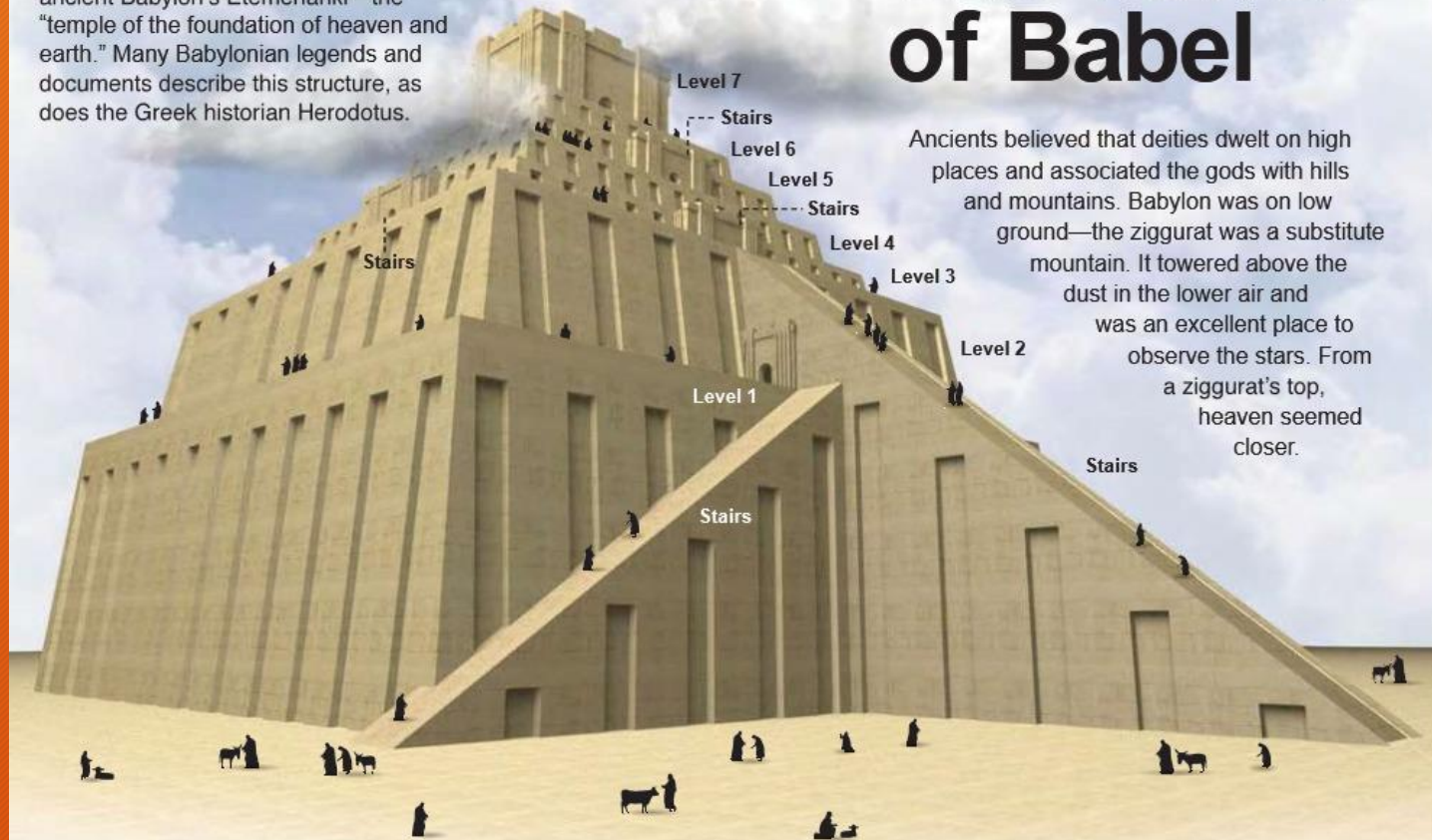

Ancients believed that deities dwelt on high places and associated the gods with hills and mountains. Babylon was on low ground—the ziggurat was a substitute mountain. It towered above the dust in the lower air and was an excellent place to observe the stars. From a ziggurat's top, heaven seemed closer.

## Size comparison (approximate):

**Great Pyramid of Giza** (tallest building in the ancient world)  
Height 480', base 755.5'

**Tower of Babel** (tallest brick-structure building of all time)  
Height 300', base 300'

**Monadnock Building** in Chicago (tallest brick-structure building now standing)  
Height 197', base 62' (16 floors)

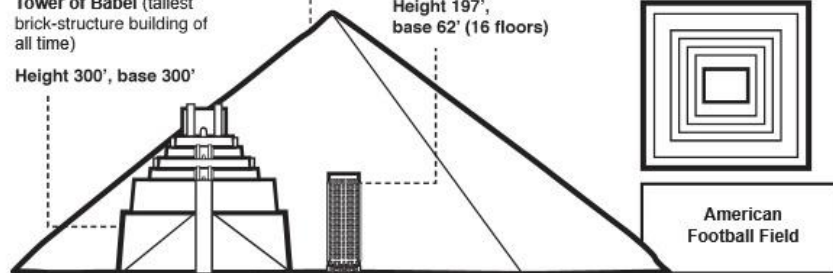

**Tower of Babel**  
(top view)

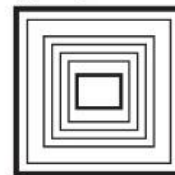

**American Football Field**

The Esagila Tablet from Uruk describes the Etemenanki with these dimensions. The stairs for the top levels are interior.

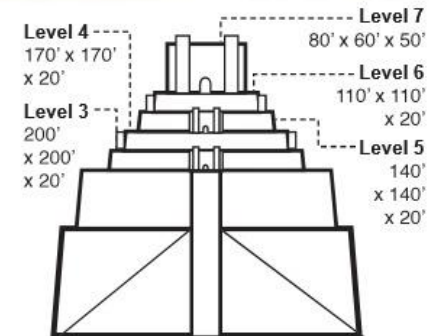



**The Ziggurat of Ur-Namma at Ur, Partially Reconstructed**





# Where Do You Get Your Name? Genesis 11:1-32

“The focus of the author since the beginning chapters of Genesis has been both on God’s plan to bless humankind by providing them with that which is ‘good’ and on the human failure to trust God and enjoy the ‘good’ that God had provided. The characteristic mark of human failure up to this point in the book has been the attempt to grasp the ‘good’ on their own rather than to trust God to provide it for them.”

John Sailhamer

# Where Do You Get Your Name? Genesis 11:1-32

“The focus of the author since the beginning chapters of Genesis has been both on God’s plan to bless humankind by providing them with that which is ‘good’ and on the human failure to trust God and enjoy the ‘good’ that God had provided. The characteristic mark of human failure up to this point in the book has been the attempt to grasp the ‘good’ on their own rather than to trust God to provide it for them.” John Sailhamer

“If true humanity is bound up in community with God and godly community with others, I will never experience it when all my eyes ever see is my own need.”  
“The more I live with the meeting of my needs as my central focus of concern, the more things in my life get defined as needs.”

“So, if my heart is ruled by the earth-bound treasures and anxiety-bound needs of the little kingdom, my search for personal treasure and my quest to meet my needs will shape the way I respond to everything in my life.” Paul Tripp

# Where Do You Get Your Name? Genesis 11:1-32

“If true humanity is bound up in community with God and godly community with others, I will never experience it when all my eyes ever see is my own need.”

“The more I live with the meeting of my needs as my central focus of concern, the more things in my life get defined as needs.”

“So, if my heart is ruled by the earth-bound treasures and anxiety-bound needs of the little kingdom, my search for personal treasure and my quest to meet my needs will shape the way I respond to everything in my life.” Paul Tripp

When you live to please yourself, circumstances that God designs to teach you to trust and obey Him instead become temptations for you to fear and worry.

John Broger

# Where Do You Get Your Name? Genesis 11:1-32

“So, if my heart is ruled by the earth-bound treasures and anxiety-bound needs of the little kingdom, my search for personal treasure and my quest to meet my needs will shape the way I respond to everything in my life.” Paul Tripp

When you live to please yourself, circumstances that God designs to teach you to trust and obey Him instead become temptations for you to fear and worry. John Broger

Worriers act as if they might be able to control the uncontrollable. Central to worry is the illusion that we can control things... The illusion of control lurks inside your anxiety. Anxiety and control are two sides of one coin. When we can't control something, we worry about it.

David Powlison

# Where Do You Get Your Name? Genesis 11:1-32

Worriers act as if they might be able to control the uncontrollable. Central to worry is the illusion that we can control things... The illusion of control lurks inside your anxiety. Anxiety and control are two sides of one coin. When we can't control something, we worry about it.

David Powlison

It is only when we want to take our lives out of the Father's hands and have them under our own control that we find ourselves gripped with anxiety. The secret of freedom from anxiety is freedom from ourselves and abandonment of our own plans. But that spirit emerges in our lives only when our minds are filled with the knowledge that our Father can be trusted implicitly to supply everything we need.

Sinclair Ferguson

# Where Do You Get Your Name? Genesis 11:1-32

“Do you suppose that I came to grant peace on earth? I tell you, no, but rather division;

Luke 12:51

# Where Do You Get Your Name? Genesis 11:1-32

“If language is the audible expression of emotions, conceptions, and thoughts of the mind, the cause of the confusion or division of the one human language into different national dialects must be sought in an effect produced upon the human mind, by which the original unity of emotion, conception, thought and will was broken up. This inward unity had no doubt been already disturbed by sin, but the disturbance had not yet amounted to a perfect breach.”

Keil/Delitzch



# Where Do You Get Your Name? Genesis 11:1-32

Then the LORD God said, “Behold, the man has become like one of Us, knowing good and evil; and now, he might stretch out his hand, and take also from the tree of life, and eat, and live forever”— 23 therefore the LORD God sent him out from the garden of Eden, to cultivate the ground from which he was taken. 24 So He drove the man out; and at the east of the garden of Eden He stationed the cherubim and the flaming sword which turned every direction to guard the way to the tree of life.

Genesis 3:22–24

# Table of Nations (Genesis 10:1-32)

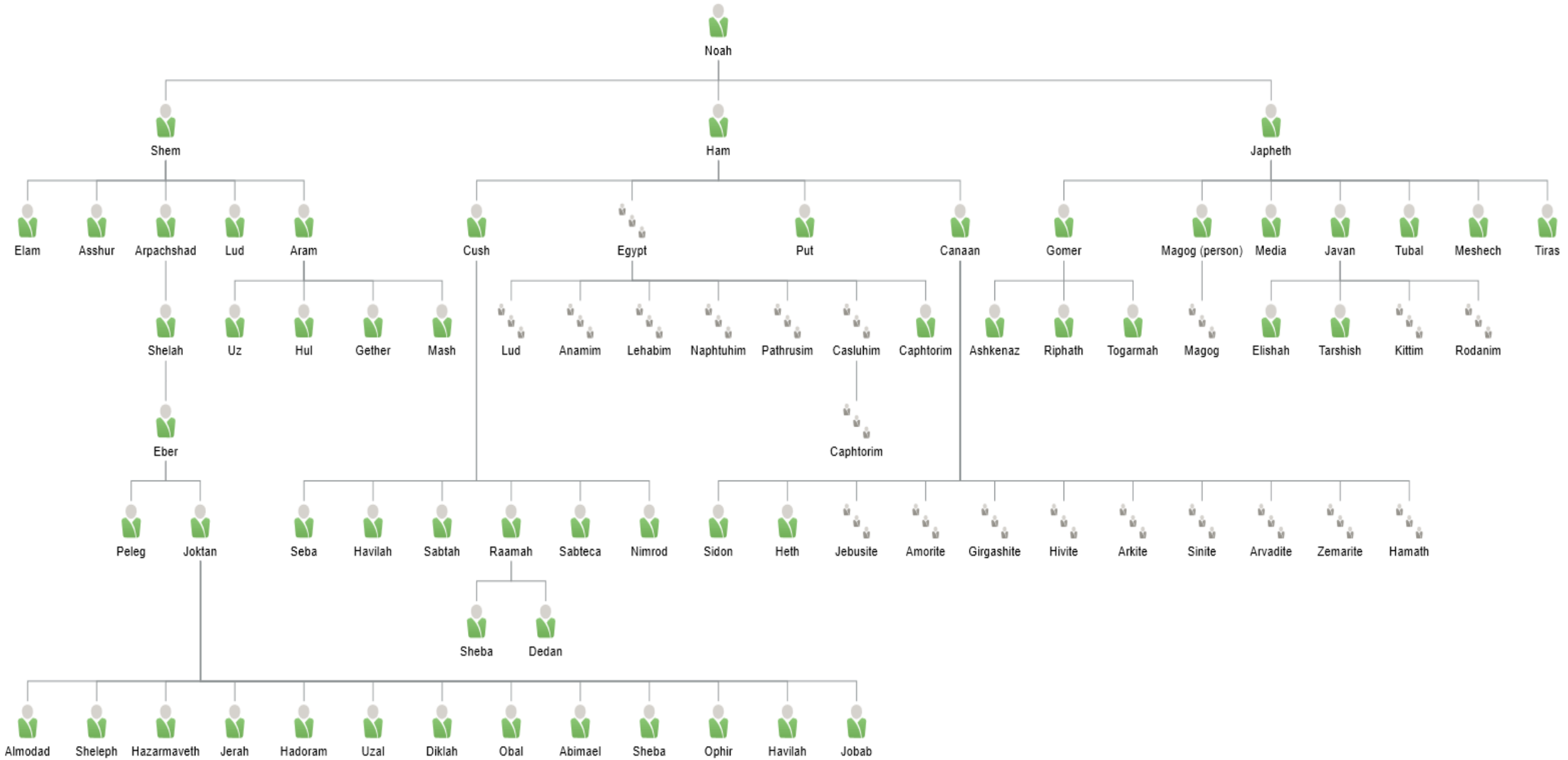

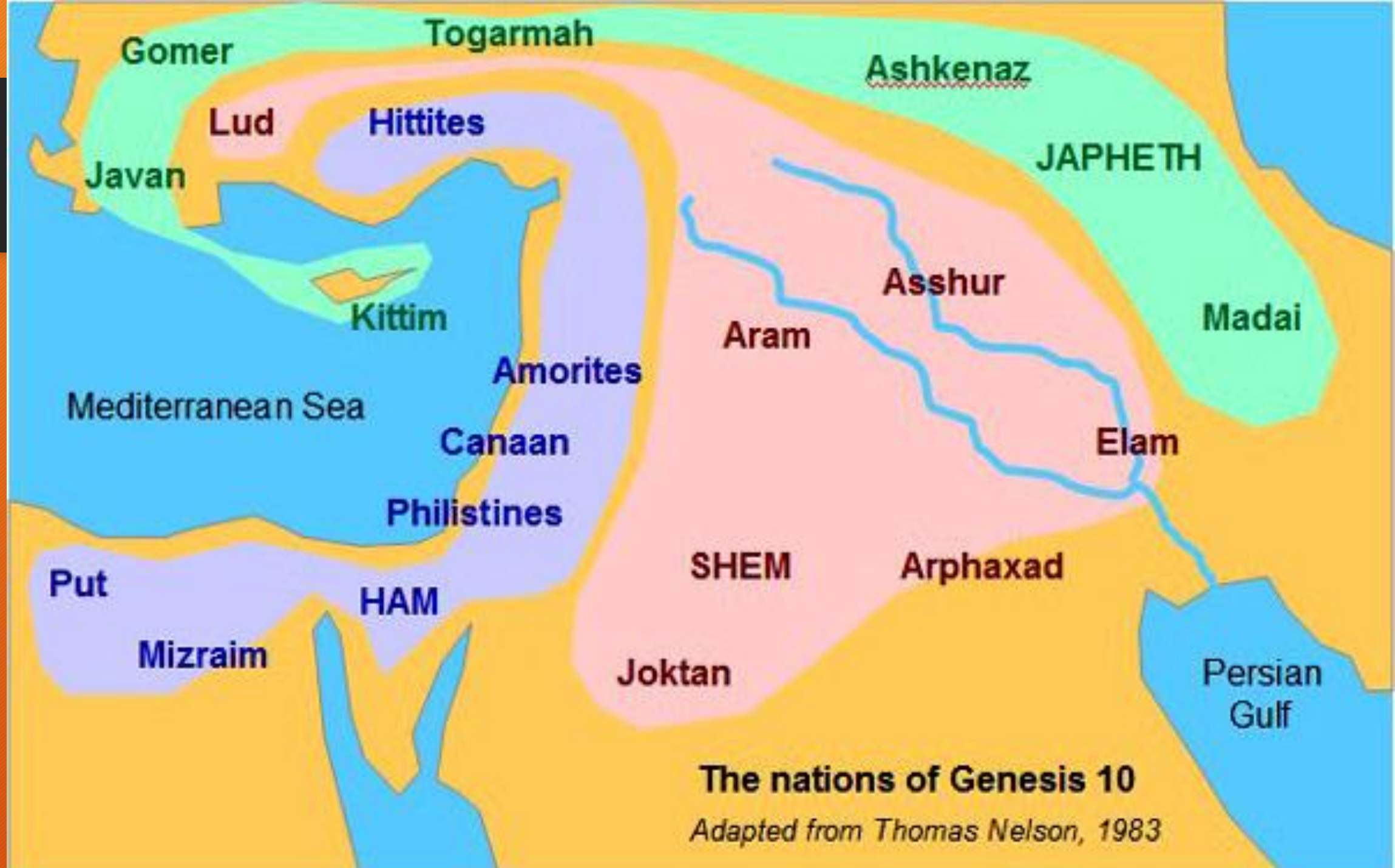

# Where Do You Get Your Name? Genesis 11:1-32

- I. A Legacy From Earth to Heaven vv. 1-9
- II. A Legacy From Heaven to Earth vv. 10-32

# Table of Nations (Genesis 10:1-32)

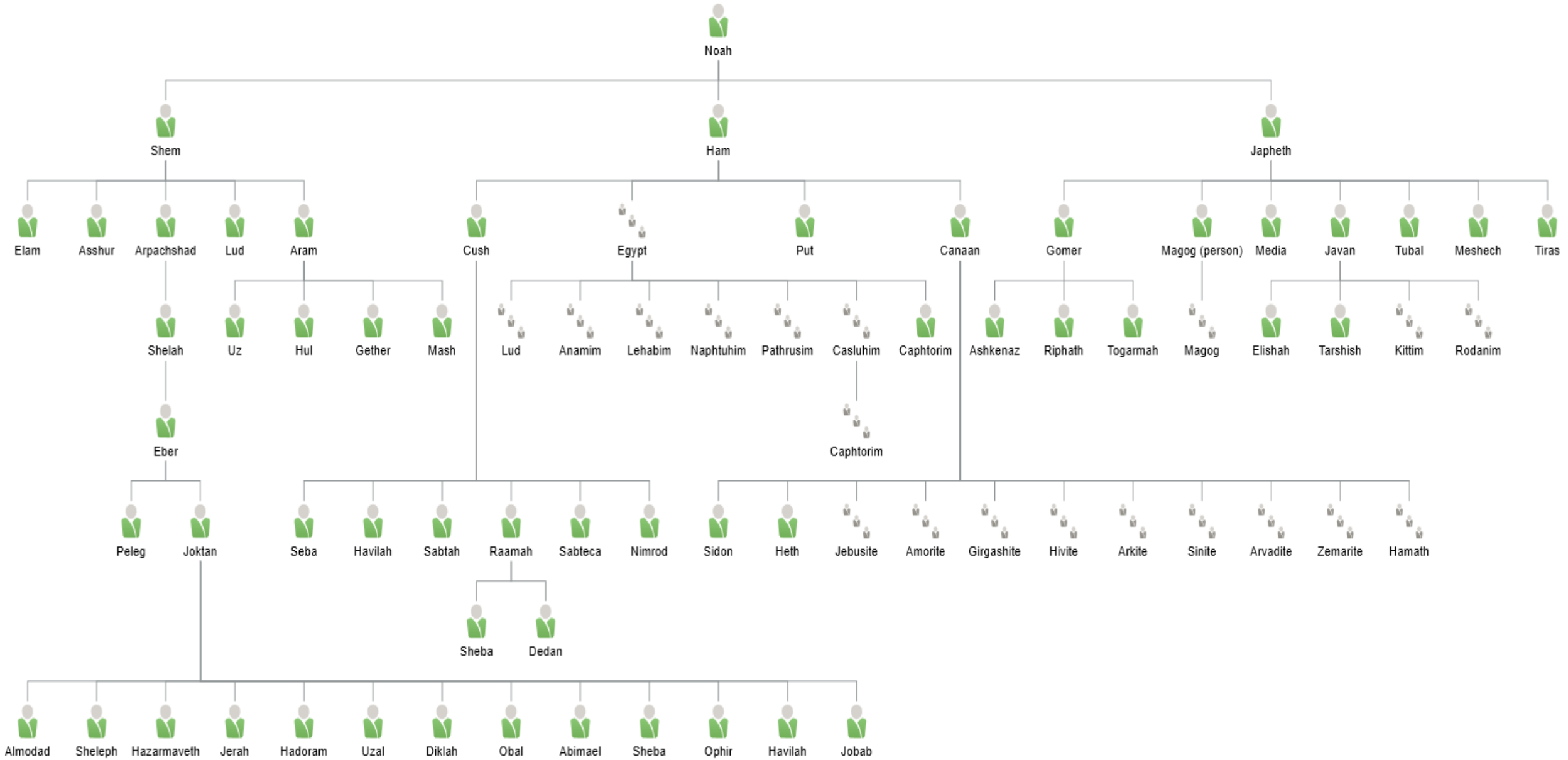



Haran

Ur?

Shechem

Bethel

Beersheba

Ur?

# Where Do You Get Your Name? Genesis 11:1-32

Joshua said to all the people, “Thus says the LORD, the God of Israel, ‘From ancient times your fathers lived beyond the River, namely, Terah, the father of Abraham and the father of Nahor, and they served other gods.

Joshua 24:2

# Adam's Family Tree (Genesis 5:1-32)

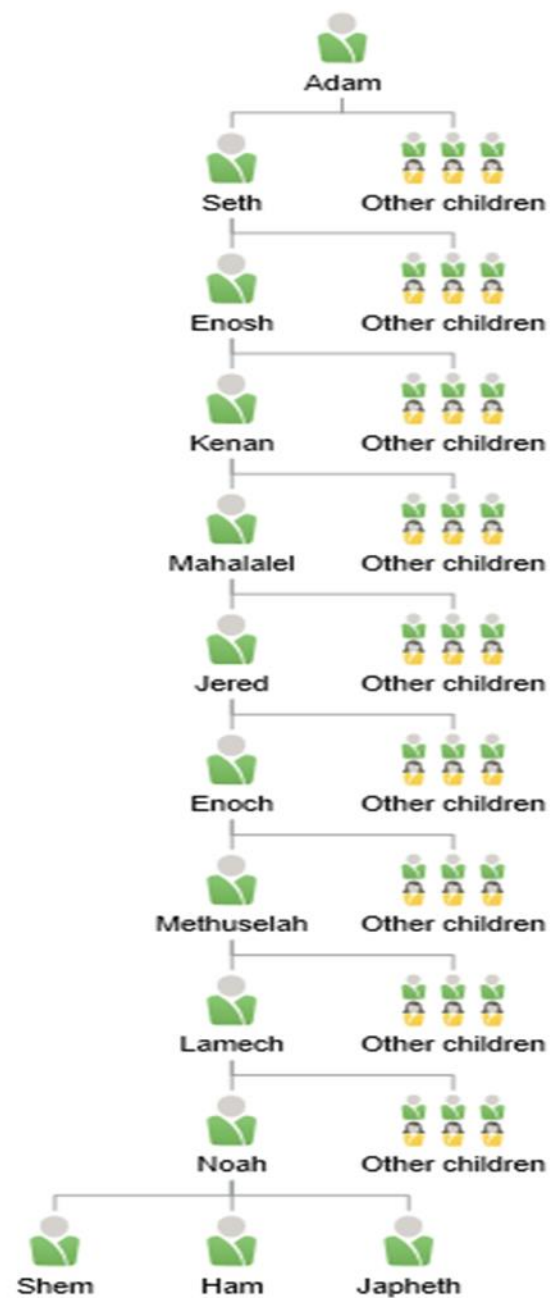



# Where Do You Get Your Name? Genesis 11:1-32

Adam had relations with his wife again; and she gave birth to a son, and named him Seth, for, she said, "God has appointed me another offspring in place of Abel, for Cain killed him." 26 To Seth, to him also a son was born; and he called his name Enosh. Then men began to call upon the name of the LORD.

Genesis 4:25–26

# Where Do You Get Your Name? Genesis 11:1-32

‘A faith, which laid hold of the word of promise, and on the strength of that word gave up the visible and the present for the invisible and future, was the fundamental characteristic of the patriarchs.’ “This faith Abram manifested and sustained by great sacrifices, by enduring patience, and by self-denying obedience of such a kind, that he thereby became the father of believers.”

Keil/Delitzsch

# Where Do You Get Your Name? Genesis 11:1-32

Even so Abraham BELIEVED GOD, AND IT WAS RECKONED TO HIM AS RIGHTEOUSNESS. 7 Therefore, be sure that it is those who are of faith who are sons of Abraham.

Galatians 3:6–7

# Where Do You Get Your Name? Genesis 11:1-32

“How do you stay strong in the reality gap? The answer is simple—at least in theory. You cling to the promises of God and the God of the promises. You don’t have to understand what God is up to; you just have to cling. That is the lesson that Abraham had to learn. Like so many of us, he had to learn the lesson not once, not twice, but repeatedly.”

Iain Duguid

# Where Do You Get Your Name? Genesis 11:1-32

By faith Abraham, when he was tested, offered up Isaac, and he who had received the promises was offering up his only begotten son; 18 it was he to whom it was said, "IN ISAAC YOUR DESCENDANTS SHALL BE CALLED." 19 He considered that God is able to raise people even from the dead, from which he also received him back as a type.

Hebrews 11:17–19

# Where Do You Get Your Name? Genesis 11:1-32

Without becoming weak in faith he contemplated his own body, now as good as dead since he was about a hundred years old, and the deadness of Sarah's womb; 20 yet, with respect to the promise of God, he did not waver in unbelief but grew strong in faith, giving glory to God, 21 and being fully assured that what God had promised, He was able also to perform. 22 Therefore IT WAS ALSO CREDITED TO HIM AS RIGHTEOUSNESS. 23 Now not for his sake only was it written that it was credited to him, 24 but for our sake also, to whom it will be credited, as those who believe in Him who raised Jesus our Lord from the dead, 25 He who was delivered over because of our transgressions, and was raised because of our justification.

Romans 4:19–25

# Where Do You Get Your Name? Genesis 11:1-32

Now may the God who gives perseverance and encouragement grant you to be of the same mind with one another according to Christ Jesus, <sup>6</sup> so that with one accord you may with one voice glorify the God and Father of our Lord Jesus Christ.

Romans 15:5–6

# Where Do You Get Your Name? Genesis 11:1-32

Now may the God who gives perseverance and encouragement grant you to be of the same mind with one another according to Christ Jesus, 6 so that with one accord you may with one voice glorify the God and Father of our Lord Jesus Christ.

Romans 15:5–6

‘He who has an ear, let him hear what the Spirit says to the churches. To him who overcomes, to him I will give some of the hidden manna, and I will give him a white stone, and a new name written on the stone which no one knows but he who receives it.’

Revelation 2:17